

PARTS BULLETIN

Subject: CUSTOM STEERING WHEEL KITS

Models Affected: ALL 1996 THROUGH 2003 MODEL YEAR H1 VEHICLES

BACKGROUND

Two Custom Steering Wheel Kits PN 5745853 and PN 5745854 are available through the DCS. Kit PN 5745853 features an all black vinyl wheel. Kit PN 5745854 contains a black and tan leather wrapped wheel. In both kits, the horn is moved to the center of the steering wheel and includes a steering wheel, a horn contact assembly, installation instructions, and all the necessary mounting hardware.

INSTALLATION TIME

The recommended installation time for the Custom Steering Wheel Kit is 0.5 hour and is paid by the customer.

WARRANTY

The Custom Steering Wheel Kit is covered under the provisions of the warranty policy. For purposes of ensuring that the subject HUMMER Approved Accessory is covered by the appropriate warranty, use the DCS and the following labor operation code to register the sale of this item. An administrative allowance of 0.1 hour will be paid for registering the sale. Labor operation 041317.

INSTALLATION INSTRUCTIONS FOR THE CUSTOM STEERING WHEEL KITS PN 5745853 AND 5745854

The following parts are contained in kit PN's 5745853 (black) and 5745854 (black/tan)

ITEM	DESCRIPTION	PART NUMBER	QTY
1.	Installation Instructions	5745852	1
2.	Horn Brush Contact	6016500	1
3.	Screw	6017428	1
4.	Steering Wheel (black/tan leather)	6016377	1
5.	Steering Wheel (black vinyl)	6017131	1

PROCEDURE

1. Remove the screws securing the steering wheel center cover to the steering wheel and remove the cover.

Note: Make sure the steering wheel is aligned in the straight driving position before it is removed. The new steering wheel does not have a keyed spline and can be installed with the steering wheel off center.

2. Remove the nut securing the steering wheel to the steering column and remove the steering wheel.
3. Lower the driver side close out panel.
4. Remove the screws securing the steering column upper shroud to the lower shroud.
5. Disconnect the original horn switch (turn signal stalk) connector from the horn harness. (See Figure 1)
6. Install the new horn brush contact in the brush plate and secure with the screw provided.
7. Connect the horn brush contact connector to the harness.
8. Install the new steering wheel and tighten the nut to 35 lb.-ft (47 N•m) (See Figure 2).
9. Plug the horn button wires in and install the button.
10. Check for proper horn operation.
11. Install the upper and the lower steering column shrouds.
12. Install the close out panel.
13. Road test with caution to verify that the steering wheel is securely fastened and is aligned correctly.

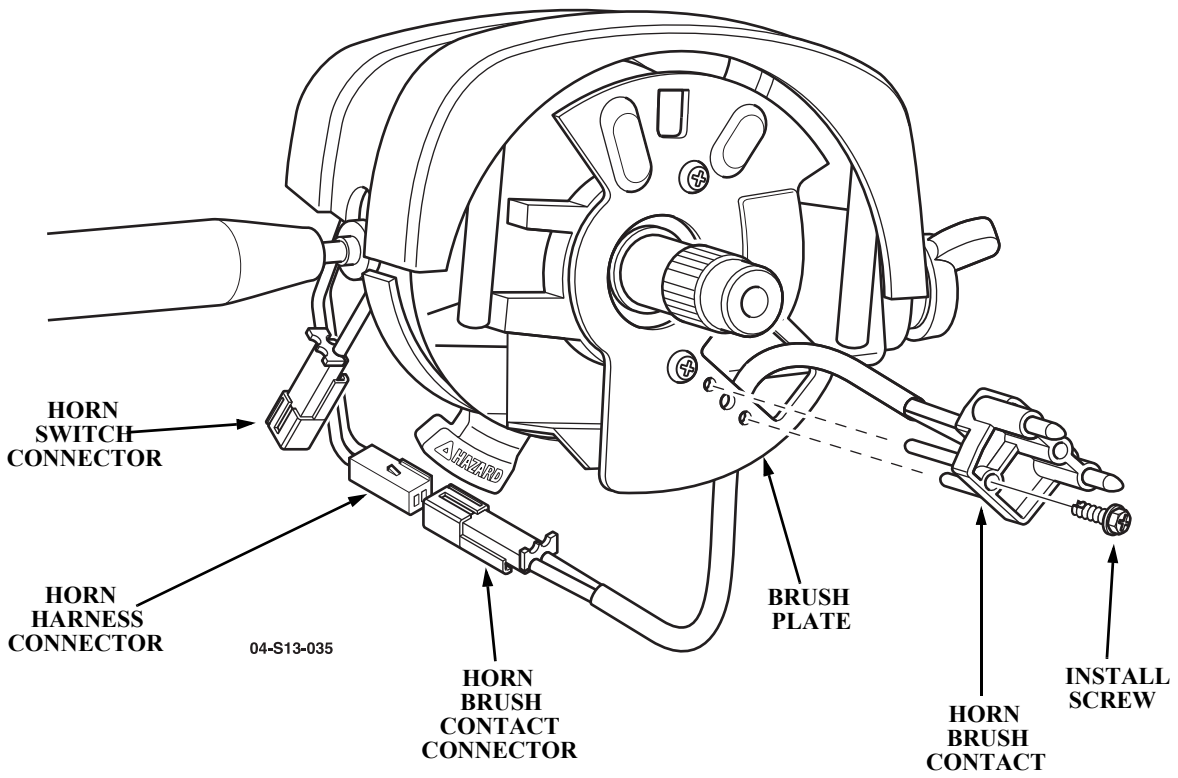

Figure 1: Steering column.

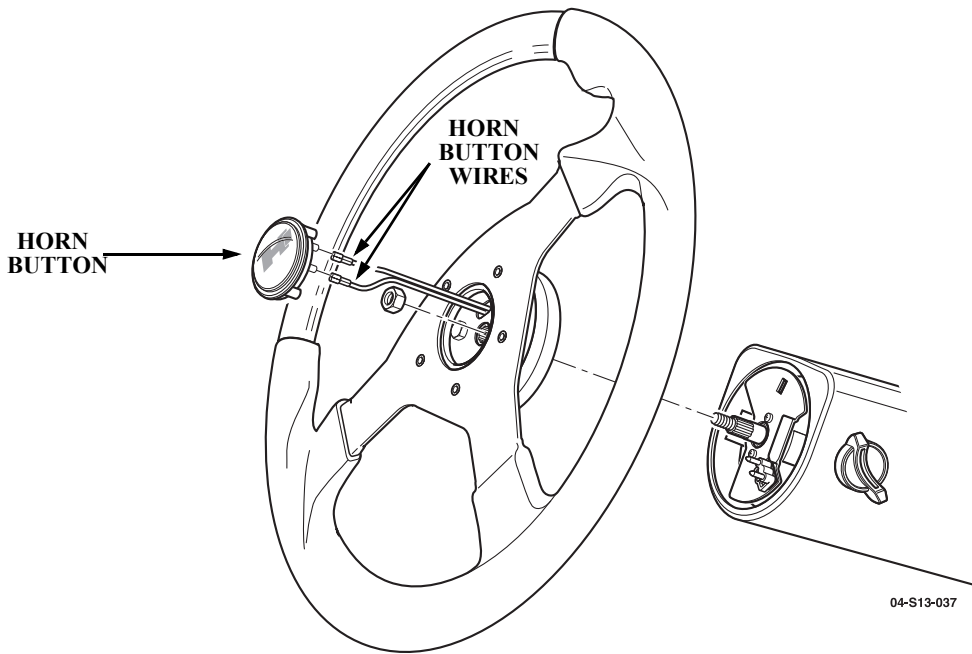

Figure 2: Steering wheel and horn button.